

PLASTIC 19.5" FENDER INSTALLATION

PRODUCT OF **SWITCH-N-GO**
A Division of Fleet Engineers Corporation

PARTS INCLUDED

QTY	PART NUMBER	DESCRIPTION
2	3170841	Spray Master Full Round 19.5" Plastic Fenders
2	3170178	Spray Master Adjustable Mounts
4	3170347	Spray Master Slidetrax Clamps

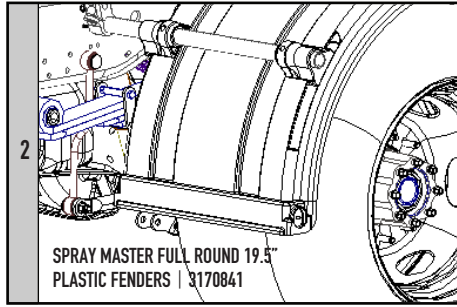

TOOLS REQUIRED

- SOCKET WRENCH
- 9/16" SOCKET
- 15/16" SOCKET
- 15/16" OPEN ENDED WRENCH
- 3/16" ALLEN WRENCH
- SOFT MALLET

⚠ WARNING // Always wear personal protective gear

ⓘ NOTICE // These instructions for installing Black Molded Nylon 19.5" Plastic fenders & mounting kit supplied by Fleet Engineers® are intended to be a general guide to help the installer. Because of the large number of possible mounting configurations, the installer is responsible for the installation design and for providing adequate clearance around the tire carrier (i.e. tire clearance, trailer clearance, etc.). These products may not fit all truck models or types of suspensions. Check truck or trailer manufacturer for suspension travel specifications. Modifications to the brackets and/or the fenders may be required. Any modifications are at the discretion, responsibility and risk of the installer.

INSTALLATION

- 1** Position fender over tires. Use a 2x4" block or other spacer to achieve desired clearance around tires. S.A.E. recommendation is 3" minimum (below the ribs).

NOTE: If you have an air suspension make sure there is tire clearance when the suspension is deflated.

- 2** Assemble the mounting clamps by inserting the threaded T-nuts into the clamps from the inside and pushing them into place. Pre-threading the 3/8-16 set screw to hold the T-nut in place, but not tight.

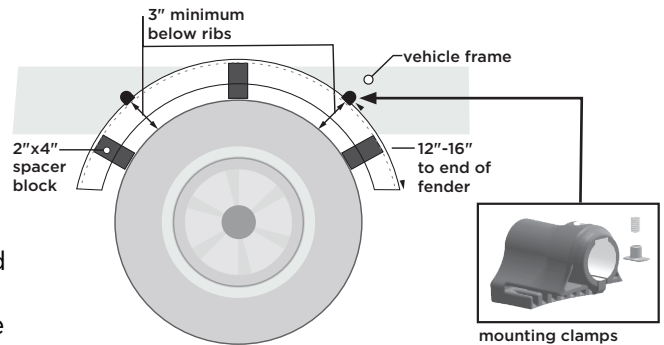

- 3** Insert a mounting tube through a mounting bracket clamp to use as a guide to position it. On the frame side of the fender, position the clamp (with tube) on the fender slides. Move the clamp on the fender slides as necessary to allow room to mount new brackets to frame.

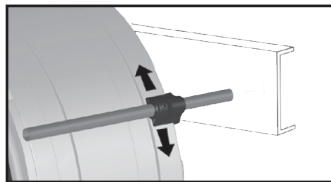

- 4** Once the position of the mounting tube is chosen, slide the other mounting clamp onto the tube, making sure that they are square to the truck frame, then mark the positions of the clamps on the fender.

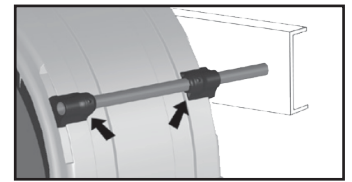

- 5** Remove the fender from over the tire and place the mounting clamps on the fender at the marked positions. Engage the mounting bracket teeth and firmly push clamps onto the fender until they snap into place. Once in place, rap with a soft hammer to seat the clamp into the fender slides.

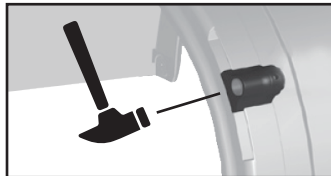

- 6** Attach the mounting tubes to the truck frame according to the instructions provided with the mounts. Make sure new brackets are straight.

NOTE: It may be easier to leave the bolts loose enough to allow some movement until the final positioning of the fender.

CONTINUED ON PAGE 2 

INSTALLATION

◀ CONTINUED FROM PAGE 1

- 7** Slide the fender with attached mounting clamps onto the mounting tubes already attached to the hoist brackets.
- 8** Position the fender over the tires and secure in place by tightening all bolts to the proper torque and installing the set screws in the mounting bracket clamps and tightening to maximum torque of 4 ft-lbs, (+/- 3in-lbs).

REPEAT STEPS 1-8 FOR EACH FENDER

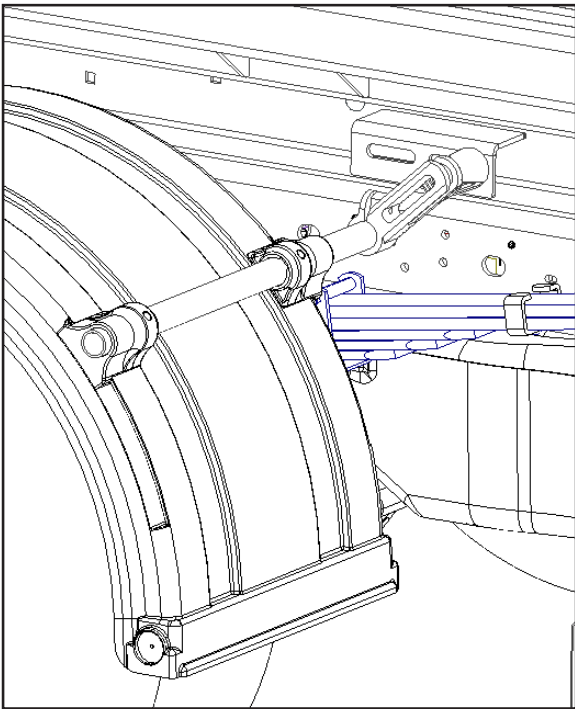

i NOTICE // Flap weights ARE NOT recommended and may void the fender warranty.

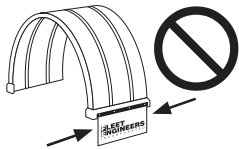

i NOTICE // Painting Spray Master® fenders IS NOT recommended and may void the warranty. If painting is desired, a flex agent MUST be added to the paint.

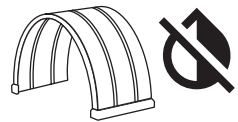

TORQUE CHART

GRADE 8	3/8-16	50 ft-lbs	5/8-11	245 ft-lbs	3/4-10	425 ft-lbs
GRADE 5	3/8-16	38 ft-lbs	5/8-11	175 ft-lbs	3/4-10	300 ft-lbs