



OPERATOR MANUAL GEN 3

S-103

PN: 1800031



REGISTER YOUR HOIST SYSTEM

Improve your Switch-N-Go® experience by taking a few minutes to register your hoist system.

To register your hoist system, you will need the following information:

- Hoist System Model Name (Ex. XX-XXXX-XXX-XXX)
- Serial Number (found on the driver's side of the hoist system)
- Proof of Purchase (invoice or bill of sale)
- Install Company Information

You can find more about this information on page 15, UNDERSTANDING YOUR HOIST SYSTEM.

Once all required steps are completed, select REGISTER at the bottom of the form to receive confirmation of your hoist system registration.

Hoist Registration

To register your hoist system, please scan the QR code or follow the link below.



<https://portal.switchngo.com/technical-support/forms-registration/hoist-system-warranty-registration/>

Truck Body Registration

To register your truck body, please scan the QR code or follow the link below.



<https://portal.switchngo.com/technical-support/forms-registration/body-warranty-registration/>



Table of Contents

General Warnings	6	Operational Weight Capacities	32
Warning Indicators	6	Calculating the Maximum Cargo Weight	32
Operator Precautions	7	Calculating the Actual Cargo Weight	33
Winch Precautions	7	Density of Materials	34
Hoist System Warnings	9	Maintenance & Repairs	36
Winch Warnings	11	Replacement Parts	36
Safety Decals	12	E-SERIES Hoist System Parts	36
Hoist System Diagram	13	H-SERIES Hoist System Parts	38
Common Parts Diagram	13	Mounting Bracket Information	40
Common Truck Body Diagrams	14	Body Prop Rod Warnings & Use	41
Switch-N-Go® Hoist System	15	Operate the Body Prop Rod	42
Understanding your Switch-N-Go® System	15	System Maintenance	43
E-SERIES Requirements	18	Winch Cable Replacement	45
Electric Winch Ratings	18	Winch Cable Installation	45
Adjusting Hydraulic Pressure	18	Hoist System Hydraulic Fluid Change	46
H-SERIES Requirements	19	Lubricating the Hoist System & Bodies	48
Hydraulic Winch Rating	19	Grease Fitting Diagram	48
Adjusting Hydraulic Pressure	20	Lubricating the Winch Cable	49
Hoist System Operation	21	System Test & Pre-Operation Checklist	50
Operating Precautions	21	Appendix	52
Operating the Control Pendant	22	Torque Table	52
Loading a Truck Body	23	Control pendant Pin-out Diagram	52
Unloading a Truck Body	27	System Diagram {E-SERIES}	53
Dumping Cargo	30	System Diagram {H-SERIES}	54
Attaching the Cable Hook	31		
Removing the Cable Hook	31		

KNOW YOUR TRUCK. Practice operating your system safely. Keep your truck in safe operating condition with the correct and proper maintenance.

Do not consume/use drugs or alcohol before or during operating/driving of machinery



Always maintain a safe operating distance to vehicles, structures or surroundings



WARNING INDICATORS

Safety decals and instructional procedures are placed in this manual, on the hoist system, and truck bodies to provide safe operating precaution or procedures to identify potential hazards. Misuse or failure to operate the system as instructed can lead to damage, serious injury or death.

⚠ DANGER

⚠ DANGER

Indicates a hazardous situation that, if not avoided, could result in serious injury or even death

⚠ WARNING

⚠ WARNING

Indicates to hazardous situation that, if not avoided, could result in minor to severe injury

⚠ CAUTION

⚠ CAUTION

Indicates a hazardous situation that, if not avoided, could result in minor to moderate injury

⚠ NOTICE

⚠ NOTICE

Indicates information considered important, but not hazard-related

OPERATOR PRECAUTIONS

You must be trained to operate a Switch-N-Go® hoist system. This operator's manual is not a training manual. It is a guide to help trained and authorized operators safely operate a Switch-N-Go® hoist system by illustrating and emphasizing the correct techniques. This manual cannot cover every possible situation that may result in an accident and the operator must watch for potential hazards during operation of the hoist system.

This product is built for hard use, but not excessive abuse. It is only as safe and efficient as the operator and person maintaining it. Do not use it for unintended purposes. Do not make any repairs unless you have been trained in safe vehicle and Switch-N-Go® hoist system procedures and/or are authorized by your vehicle/system owner. Do not operate a damaged or malfunctioning vehicle or hoist system.

WINCH PRECAUTIONS

The Switch-N-Go® electric system is designed for up to 6 fully loaded draws per day. A fully loaded winch draw is equal to the rating of the winch. If you are loading a lesser weight, the system will be able to pull more than six loads per day with proper cool-down periods in between. Overworking the winch will cause the electric winch motor to overheat, resulting in permanent damage. Let the winch motor cool down before resuming operation. The Switch-N-Go® hydraulic system is designed for unlimited number of winch draws and lifts per day. Before you start operating the winch or hoist system, be sure you understand all the procedures.

- Before initial use of your winch, test the system is working properly. **MAKE SURE TO KEEP HANDS AWAY FROM WINCH CABLE AND HOOK WHILE WINCH TESTING.**
- Never touch the winch cable or hook while it is in tension or under load. Even at rest, the winch cable may have tension.
- Always wear heavy-duty leather gloves when handling the winch cable as to protect hands from contact with the lubricated wire cable.
- Never handle the winch cable while another individual is operating the controls of the system or vehicle.
- Always stand clear of the winch cable and or loaded body during operation of the winch, as a cable may pull loose or break while under load this can cause damage or injury. Always be mindful of your own safety and the safety of others.



- Always be certain the cable that you intend to use is capable of withstanding the load.
- Operate the winch with common sense and never wrap the cable around an object or a person and hook it back to the winch cable as this will cause damage or injury.
- The winch must maintain a minimum of 5 wraps on the drum in the direction indicated on the winch. With fewer wraps, the winch cable could break loose from the drum under heavy load.
- The spool direction of the winch cable can accidentally be reversed by running the winch cable all the way out and respooling in the opposite direction causing the winch to spool "IN" when the "OUT" button is pressed.
- Never exceed the rated capacities of the system's winch or vehicle's (GVWR) when lifting a loaded body.
- Always load a body in-line with the hoist system to minimize the coil buildup of winch cable on only one end of the spooling drum.
- Operate the winch controls smoothly and reduce any slack to avoid shock loads which can momentarily exceed the winch and winch cable rating.
- The life of the winch cable is directly related to the care it receives. New winch cables or replacement winch cables **MUST BE STRETCHED AND RESPOOLED UNDER LOAD** before operating the winch. Failure to do this will result in premature winch cable damage.
- To prepare the winch for heavy loads, un-spool the winch cable and tightly level wind winch cable onto the drum. This will minimize winch cable damage, such as mashing and kinking, caused from top layers pulling down into bottom layers when short pulls are made. The greatest loading power is available at the first layer on the drum, decreasing with each successive coil.
- Always inspect winch cable for mashed, pinched, or frayed areas prior to loading a body. This greatly reduces the original tensile strength of the winch cable and it should be replaced if there are any cable issues found.



- When spooling "IN" the winch cable, be sure to distribute the winch cable evenly and tightly onto the drum. This prevents the top layers of winch cable from being drawn into the bottom layers of the winch cable and creating a bind. If the winch cable binds on the drum, the winch and/or winch cable may be damaged. A bound winch cable will reel OUT only a short distance and then reel back IN even though the "OUT" button is being pressed. A bound winch cable must be corrected before using the winch. Should the winch cable become bound, connect the hook to a load, then by alternating the winch "IN" then "OUT", the winch cable will usually work itself free. **DO NOT PUT YOUR HANDS ANYWHERE NEAR THE WINCH CABLE WHEN WORKING A BIND FREE.**
- Before using the electric winch, inspect the control pendant cord for cracks, pinched spots, frayed wires, or loose connections. A damaged or shorted cord could cause the winch to operate incorrectly.

HOIST SYSTEM WARNINGS

DANGER

Bouncing or jerking of the hoist system is to be avoided as it may result in component failure, injury or death.

DANGER

Do not raise or drive a raised body against another object. Doing so could result in equipment or property damage, injury or death.

WARNING

The hoist system cylinder shall not serve as a structural member to absorb side loads; the cylinder shall only provide a lifting force along the axis of the cylinder. No force acting radially to the cylinder should be applied to the cylinder as damage could result.

⚠ WARNING

Do not operate hoist system until bystanders are free and clear of the hoist system and body.

⚠ WARNING

Never exceed the Gross Vehicle Weight Rating (GVWR) or the Gross Axle Weight Rating (GAWR) of your vehicle. Overloading a truck can cause component damage, injury or death.

⚠ CAUTION

Unlatch tailgate prior to elevating a loaded dump body as excessive forces on the rear of the dump body may result in component failure.

⚠ CAUTION

Never operate the hoist system on unlevel or soft terrain as this may cause component damage and/or the vehicle to rollover.

⚠ CAUTION

Relieve pressure before disconnecting hydraulic lines. Tighten all connections before applying hydraulic pressure. Protect hands, eyes, and body from high-pressure fluid leaks. Wear protective eyewear and gloves when accessing the hydraulic system or searching for leaks.

⚠ WARNING

Never place any body part between the hoist system scissor action and hoist system frame unless the body prop rod is engaged to hold up the hoist system. Use the body prop rod to hold the hoist system upright when certain kinds of equipment maintenance are to be performed.

⚠ WARNING

DO NOT CHANGE THE CONTROL PENDANT CORD LENGTH. The length of the cord has been carefully determined to decrease the chance of the operator injury during the loading and unloading process.

⚠ WARNING

Be AWARE of your surroundings when operating the hoist system/winch from inside the truck cab. It is recommended that you operate the hoist system alongside of the vehicle to observe the loading/unloading process.

WINCH WARNINGS**⚠ CAUTION**

Do not exceed the line pull rating shown on the winch identification label. Exceeding the winch pull rating will abuse the motor and cause failure. Do not exceed the maximum rating of the winch cable being used.

⚠ CAUTION

Do not exceed rated duty cycle of electric winch when changing bodies. The electric winches are rated for intermittent duty operation only.

⚠ CAUTION

Disconnect the control pendant when not in use as this prevents accidental activation of the hoist system or winch while driving.

⚠ WARNING

Shock loads result when the winch cable is spooled out before the body is ready to let gravity roll it off the Switch-N-Go® system. It is necessary to keep the cable tight at all times by first raising the hoist to the proper angle. Just one significant shock load with a heavy body can cause a winch failure.



SAFETY DECALS

Safety Decals only available as a complete kit and are available upon request through your local Switch-N-Go® Dealer.

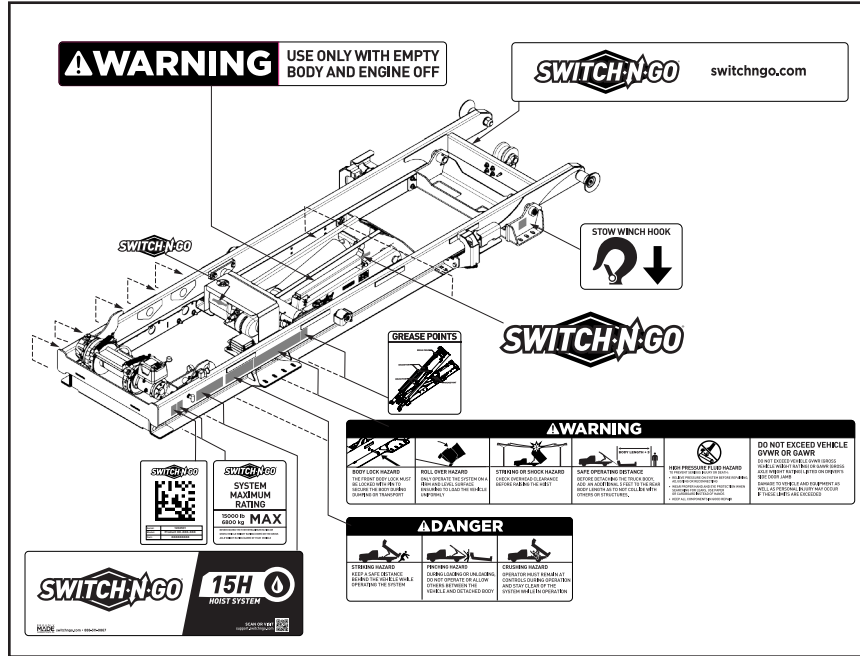

HOIST SYSTEM DIAGRAM

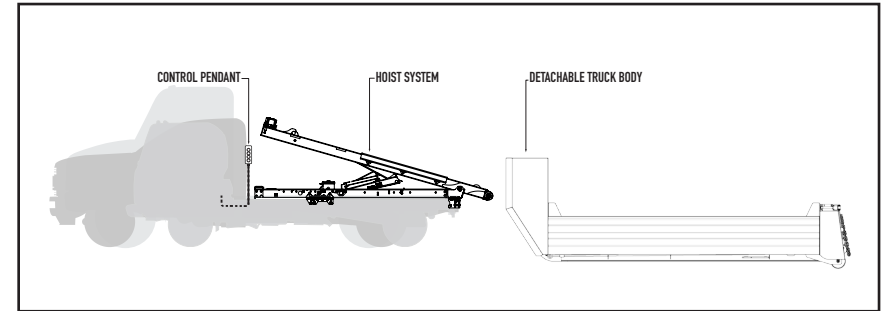

COMMON PARTS DIAGRAM

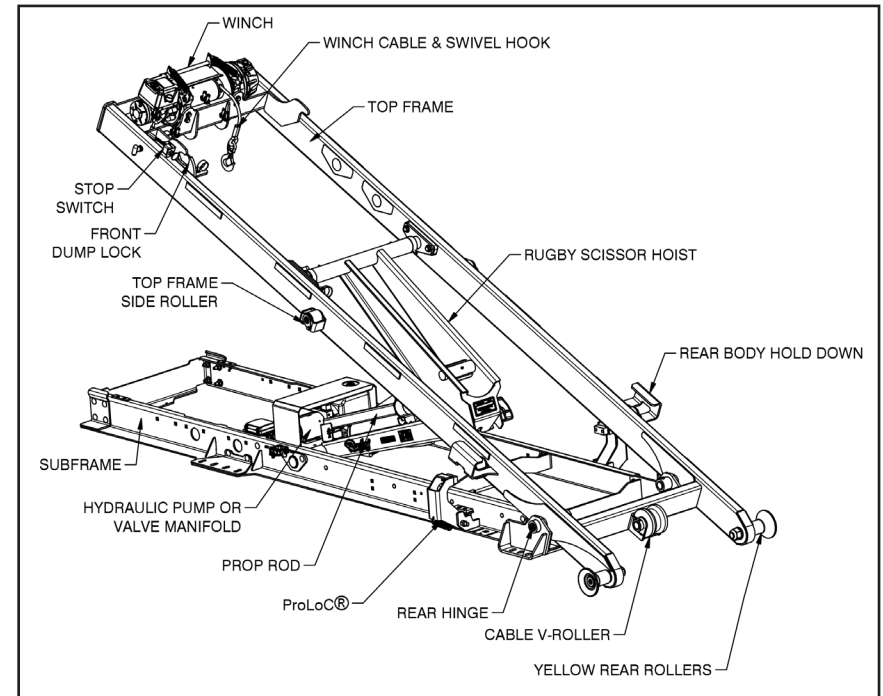

COMMON TRUCK BODY DIAGRAMS

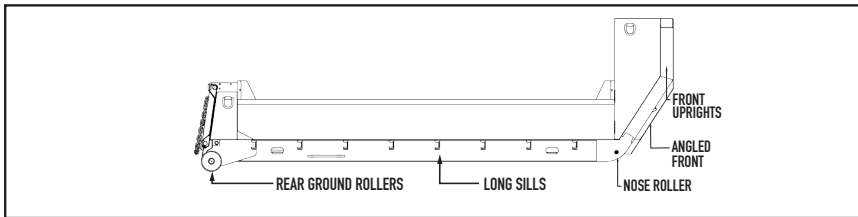
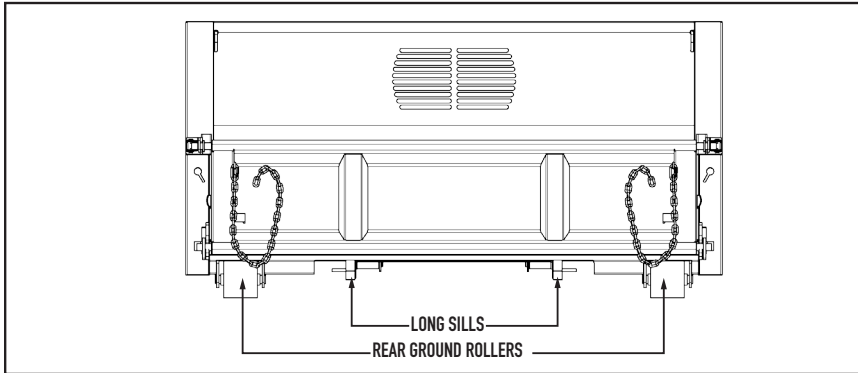
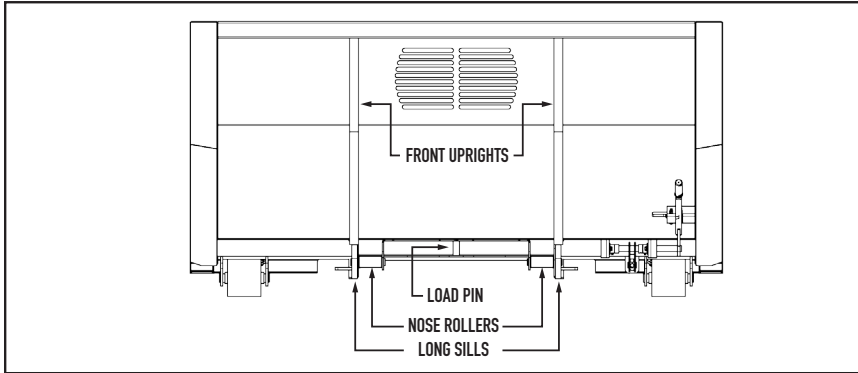

UNDERSTANDING YOUR SWITCH-N-GO® SYSTEM

Before installing or operating the Switch-N-Go® Hoist System, please review and understand the hoist system. Identify the serial/model identification tag, located on the driver's side of the Switch-N-Go® top hoist frame, near the front.

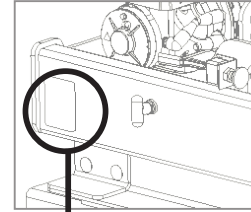

SERIAL NUMBER

This identification or serial number is unique to each model, manufacturing date, and sales order. This serial number is used for warranty claims and technical support.

MODEL NAME



The model name is based on the 4-part identification code shown on next page. This is not a unique identifier.

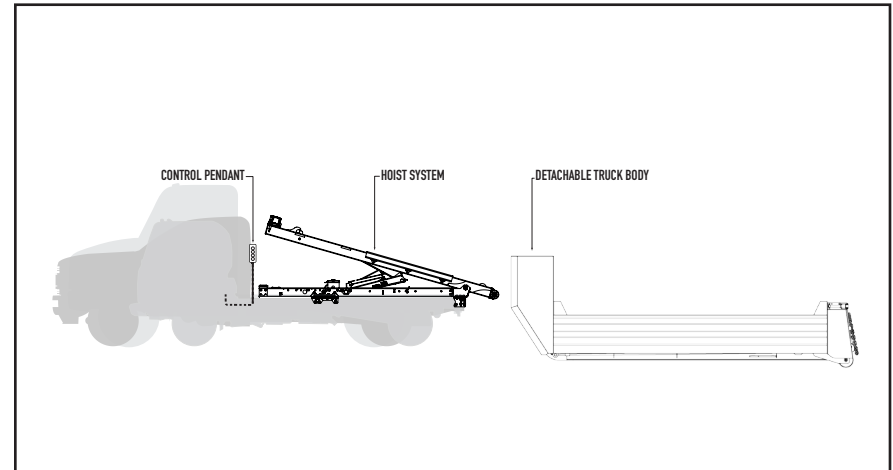

PART NUMBER

The part number helps identify your hoist system to our internal team and may be requested when contacting technical support.



 E-SERIES MODEL Indicators —	11-4016-15E-10T <div style="display: flex; justify-content: space-around; margin-top: 10px;"> 1 2 3 4 </div>
 H-SERIES MODEL Indicators —	14-5020-18H-10T <div style="display: flex; justify-content: space-around; margin-top: 10px;"> 1 2 3 4 </div>

Indicators on the example are provide below with brief descriptions of how to understand your hoist model name.

1



HOIST SYSTEM LENGTH

The Switch-N-Go® model length is unitized by foot increments. The length is less than the cab to end of frame (CEF) of the vehicle chassis ranging from 9' (108") up to 14' (168"). Systems that are shorter or longer are acceptable but require additional modifications or accessories. For additional information see your vehicle manufacturer's up-fit documents. The standard Switch-N-Go® hoist system has an 18" overhang.

2



SCISSOR HOIST SERIES

The scissor hoist system is built by Rugby™ for Switch-N-Go® hoist systems. The series can be identified by the 4-digit number in the model name: 4016, 4020, or 5020.

3



HOIST SYSTEM | E-SERIES

The Switch-N-Go® E-series (electric series) is an electric-over-hydraulic system that has a Warn electric winch and a hydraulic hoist system. This system is designed for up to 6 fully loaded draws per day. A fully loaded winch draw is equal to the rating of the winch, which is 15,000lbs. If you are loading a lesser weight, the system will be able to pull more than six loads per day. This system utilizes a hydraulic scissor hoist system, allowing for unlimited dumping. The Switch-N-Go® full electric operation system is equipped with a pre-wired electric Warn winch and a separate on-board electric-powered hydraulic hoist system. The E-series offers a winch capacity of 15,000 lbs. as indicated as by the 15 in the model name followed by an "E" for electric. This is ideal for GVWR vehicles between 13,500 lbs. - 26,000 lbs. The E-series is supplied with a 350-amp fuse, power, and ground wires in the E-series installation kit.

3



HOIST SYSTEM | H-SERIES

The Switch-N-Go® H-series (hydraulic series) is a full hydraulic system that has a Warn hydraulic winch and a hydraulic hoist system. This system is designed to handle an unlimited number of winch draws and dumps per day. This system utilizes a hydraulic pump, supplied by either a "live" drive-style power take-off (PTO) or an under-hood clutch pump for both the winch and the hoist system. The H-series offers two combined hydraulic-powered winch/hoist system capacities: 15,000 lbs. or 18,000 lbs. as indicated as by a 15 or 18 in the model name followed by an "H" for hydraulic. This is ideal for GVWR vehicles between 16,000 lbs. - 33,000 lbs. The H-series requires more components to be installed onto the truck including a hydraulic pump, reservoir, filter, and additional hoses. These components are not provided with the H-series installation kit.

3



HOIST SYSTEM | S-MODEL

The Switch-N-Go® S-model hoist system has a shorter 6" overhang for easier access to the hitch under the truck body. This is shown in the model name by an "S" following the winch type indicator. Limited models are offered in this configuration.

4



HOIST CAPACITY

The dumping capacity of the hoist system differs from the pulling capacity of the winch. The last alpha-numeric indicator in the model name refers to the hoist system capacity. For example, 10T would indicate the hoist system is capable of dumping 10 tons.



E-SERIES REQUIREMENTS

The electric-over-hydraulic system does require components that are provided in the E-Series installation kit during hoist system installation. This system requires that one 350-amp ANL fuse and fuse holder be installed within the vehicle's engine compartment, within 18" of the battery.

Additional Vehicle Installation Components

- Alternator - A heavy duty alternator with a 150 AMP minimum capacity
- Batteries - Two deep cycle 750 CCA or greater batteries
- Fluid - 7.5-12 quarts of hydraulic oil equivalent to Grade 32 (such as ATF-Dextron II or Mobile DTE 13)

⚠ CAUTION

Make sure to test that the alternator and batteries are functioning properly and meet the system requirements as stated. Failure to meet the requirements may result in a weak or non-functioning system.

⚠ WARNING

The battery is capable of providing its unlimited current in the event of a short circuit. If a short circuit occurs, damage to the wiring system or a fire may result. Fuses provide the most reliable circuit protection. Failure to provide circuit protection may result in a fire or damage the vehicle. A 350-amp ANL fuse is provided in the electric installation kit. Install the fuse on the battery power supply cable, as close as possible to the battery.

ELECTRIC WINCH RATINGS

Winch Reference	Maximum Body Weight	Instruction Manual	Maximum Loaded Body Pulls per Day	Winch Operation Cooldown Period
15E	15,000 lbs.	Startup Guide	Up to 6 pulls	Approximately 1 hour between maximum loaded winch pulls

ADJUSTING HYDRAULIC PRESSURE

The hydraulic system included with your Switch-N-Go® hoist system has been preset and tested at the factory. Modification to this system should not be needed and doing so may void the factory warranty. Contact your installer if adjustments to the hydraulic system are needed.



H-SERIES REQUIREMENTS

The full hydraulic system requires components that are provided in the H-Series installation kit during hoist system installation. This system requires that the 15 AMP blade-type fuse and fuse holder be installed within the vehicle engine compartment, preferably near the battery and the fuse box.

Additional Vehicle Installation Components

- Pump - A hydraulic pump either a Clutch Pump or "live drive" style Power Take Off (PTO) Pump: that is capable of producing 3000 PSI pressure at a flow rate of 12-15 GPM.
- Hoses - Hose that is flame resistant and rated for use of hydraulic oil with a minimum burst pressure of 3000 PSI. Need varying lengths of the hose in both 1/2" and 3/4" diameters.
- Tank - A 15-20 gallon tank rated for hydraulic oil use with a basket strainer in the filler tube.
- Filter - An inline hydraulic filter with an internal bypass is recommended
- Fluid - 18-23 gallons of hydraulic oil equivalent to Grade 32 (such as ATF-Dextron II or Mobile DTE 13)

⚠ DANGER

Connecting the hoist system to a hydraulic system with more pressure (psi) or flow (gpm) than is recommended by the hoist system manufacturer can lead to damage, serious injury or death.

HYDRAULIC WINCH RATING

Winch Reference	Maximum Body Weight	Instruction Manual	Maximum Loaded Body Pulls per Day	Winch Operation Cooldown Period
15H	15,000 lbs.	Startup Guide	Unlimited pulls	N/A
18H	18,000 lbs.	Startup Guide	Unlimited pulls	N/A



Failure to follow pressure and flow rate specifications below may result in lower speeds, less capacity, or premature system failure.

RUGBY HYDRAULIC PRESSURE SETTINGS

Rugby SR Hoist Specifications	Maximum Hydraulic Flow Rate	Maximum Pressure for Raising Portion of Dump Cycle	Maximum Pressure for Lowering Portion of Dump Cycle
SR-4016	6 GPM	3200 psi	1000 psi
SR-4020	6 GPM	3200 psi	1000 psi
SR-5020	9 GPM	3200 psi	1000 psi

WARN HYDRAULIC PRESSURE SETTINGS

H-Series 15,000lbs Specifications	Maximum System Pressure	Maximum Motor Pressure Drop	Maximum Rated Input Flow
Warn Hydraulic Winch Specifications	2500psi	2163 psi	15 GPM
	172 BAR	149 BAR	57 LPM
	Control Valve Type: 3-Position, 4-way, closed center, spring return (cylinder spool)		

H-Series 18,000lbs Specifications	Maximum System Pressure	Maximum Motor Pressure Drop	Maximum Rated Input Flow
Warn Hydraulic Winch Specifications	2500psi	2125 psi	15 GPM
	172 BAR	146 BAR	57 LPM
	Control Valve Type: 3-Position, 4-way, closed center, spring return (cylinder spool)		

ADJUSTING HYDRAULIC PRESSURE

The hydraulic system included with your Switch-N-Go® hoist system has been preset and tested at the factory. Modification to this system should not be needed and doing so may void the factory warranty. Contact your installer if adjustments to the hydraulic system are needed.

OPERATING PRECAUTIONS

Please read all instructions before proceeding. Failure to follow these instructions could damage the vehicle or cause injury or death.



DO NOT OVER WORK THE WINCH. The electric winch can only operate for 3-5 minutes at its maximum load limit. Then, it must rest for approximately 1 hour before operating again.



The hoist system must be lowered down before securing the cable to the hook stow point located at the rear mounting bracket. Failure to do so may result in major damage to the top frame and subframe of the hoist system and cause it to function improperly.



It may be necessary to let the truck drive under the load to minimize the stress on the winch when the terrain will not permit normal loading. The operator must be in the truck cab for this style of loading.



During freezing weather it is recommended that the body be placed on blocks so that it does not freeze to the ground. Pulling a body frozen to the ground can cause excess stress on the winch.



OPERATING THE CONTROL PENDANT

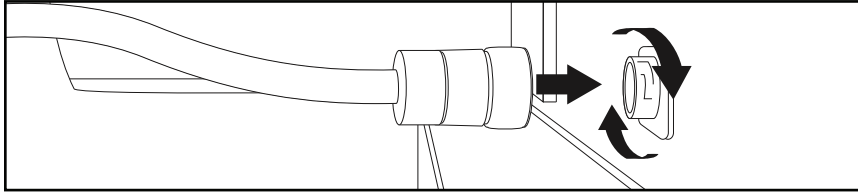

- Step 1—** Connect the control pendant to the in-cab pendant receptacle.
- Step 2—** Refer to the diagrams below to learn the buttons functions.

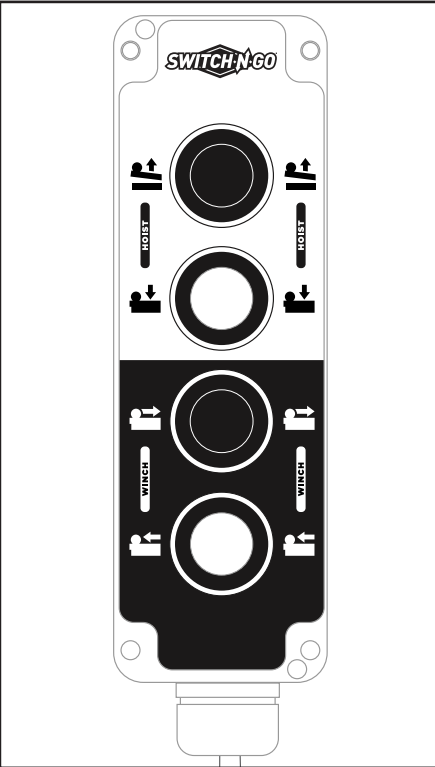

[HOIST]
—
HOIST UP

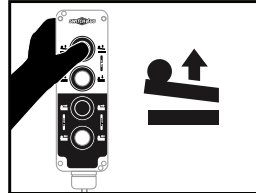

[HOIST]
—
HOIST DOWN

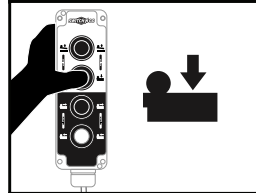

[WINCH]
—
WINCH OUT

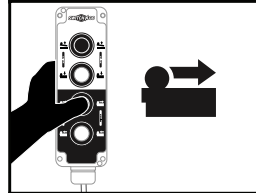

[WINCH]
—
WINCH IN

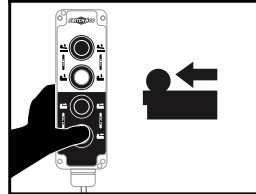

! WARNING

Before lifting any heavy load, review this loading precautions checklist:

- Check that the safety keeper on the winch cable hook is securely closed around the truck body load pin before dumping.
- Check that the winch is in working condition and will withstand the load of truck body and load during dumping.
- Check to be sure that no individual is behind the vehicle and truck body.
- Check that there is sufficient height clearance so that unloading is not obstructed by over-head obstacles.

! CAUTION

Ensure the vehicle is on a level and firm surface away from any overhead obstructions.



SCAN THIS CODE

to see an instructional video or visit us at <https://portal.switchngo.com/technical-support/technical-documents/#operator>

LOADING A TRUCK BODY

- Step 1—** Locate and make sure body lock pin is pulled out and twist to lock into open position. This will allow the body lock plate to swing open.

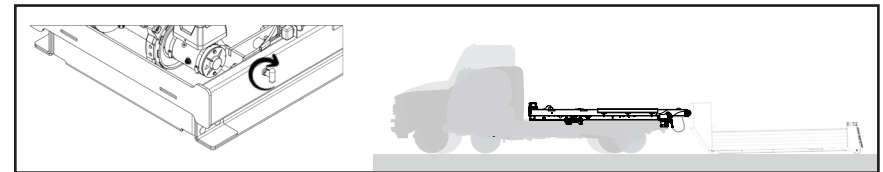

- Step 2—** Attach the cable hook to the load pin on the truck body. Ensure the safety keeper on the cable hook is securely closed. See Attaching the Cable Hook instructions on page 31 for more detail.
- Step 3—** Slowly pull your truck forward, putting slight tension on the cable.
- Step 4—** Connect the control pendant to a control receptacle located either inside the vehicle's cab.
- Step 5—** Before putting the truck in neutral, ensure it is on level ground. Press the button marked winch "IN" while ensuring the winch cable is properly directed through the center V-roller. This will draw the truck closer to the body. The truck body's front uprights should be centered between the yellow rear rollers.
- Step 6—** Press the button marked hoist "UP" using the reference below as a guide:

State of Truck Body	Initial Angle of Hoist
Empty / Unloaded	25° - 30°
Full / Loaded	50° - Full Height

- a** When loading with the operator outside the vehicle cab, make sure to ENGAGE THE VEHICLE'S PARKING BRAKE.
- b** When loading with the operator inside the vehicle cab: DISENGAGE THE VEHICLE'S PARKING BRAKE AND PLACE THE VEHICLE IN NEUTRAL. This will allow the vehicle to drive under the loaded body as you pull the winch "IN".

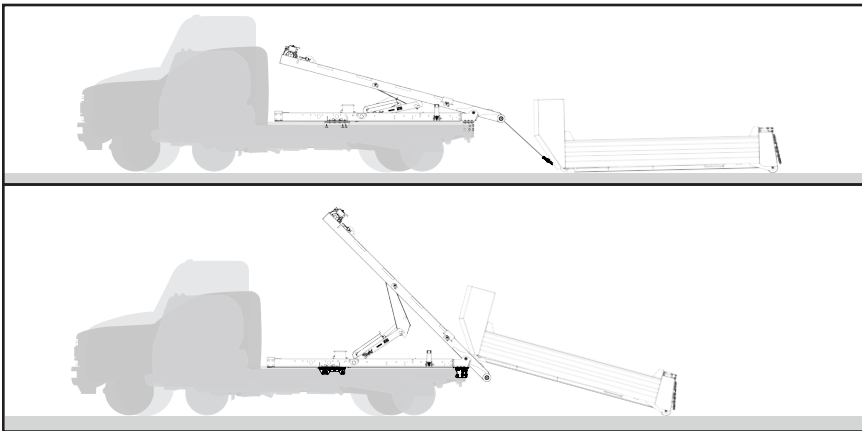

- Step 7—** When the body's long sills (bottom rails) reach the yellow rear rollers, press the button marked hoist "DOWN" to nearly match the angle of the body's runner rails.

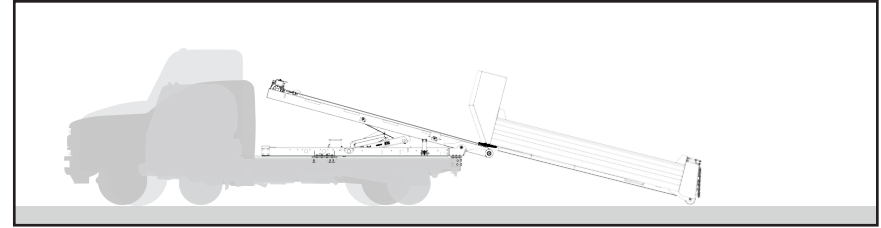

- Step 8—** Press the button marked winch "IN" until the truck body's rear rollers are off the ground.

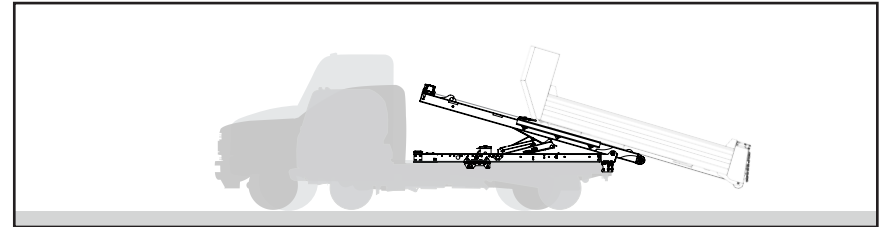

⚠ DANGER

If the vehicle's front wheels lift off the ground at any time, This is an OVERLOADED, UNSAFE CONDITION. Unload the body and lighten the load, then restart the loading procedure.

- Step 9—** Press the button marked hoist "DOWN" until the top frame is about 10" above the subframe, as this will relieve the winch draw due to pulling the truck body against the force of gravity.

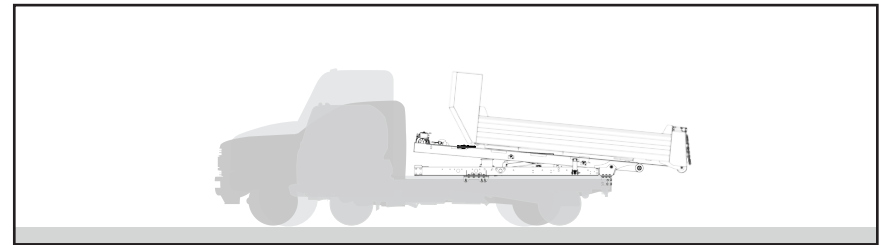

- Step 10—** Press the button marked winch "IN" at this lower angle until the truck body comes against the front stops. The winch stop switch will shut-off and halt winching the body inward.

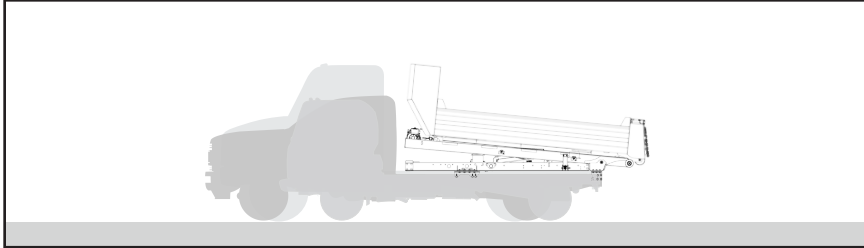

- Step 11—** Press the button marked hoist "DOWN" to rest the top frame onto the subframe of the hoist system. This closes the dump lock and secures the body to the hoist system.

NOTE

Do not lower the hoist system down entirely before the winch cable is retracted all the way, otherwise the body will not be secured into the dump lock.

- Step 12—** Locate and pull dump lock pin and twist to release, this will allow pin to retract into top frame and secure the dump lock.

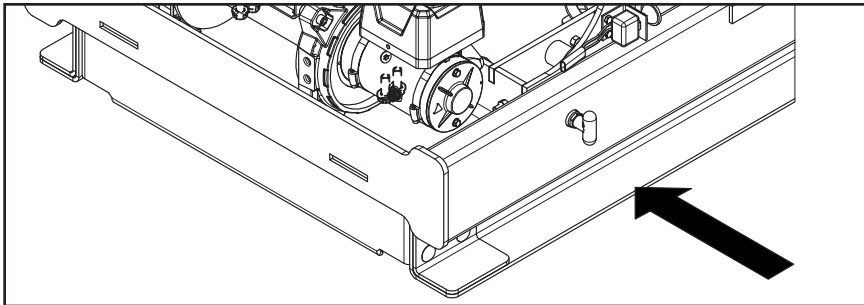

- Step 13—** Disconnect control pendant from the control receptacle and safely stow away inside the cab.

WARNING

Before lifting any heavy load, review this loading precautions checklist:

- Check that the safety keeper on the winch cable hook is securely closed around the truck body load pin before dumping.
- Check that the winch is in working condition and will withstand the load of truck body and load during dumping.
- Check to be sure that no individual is behind the vehicle and truck body.
- Check that there is sufficient height clearance so that unloading is not obstructed by over-head obstacles.

CAUTION

Ensure the vehicle is on a level and firm surface away from any overhead obstructions.

UNLOADING A TRUCK BODY

- Step 1—** Position the vehicle's body ensuring there is enough space to unload the body and add 5 feet of working space behind the truck body once unloaded from the vehicle.
- Step 2—** Locate dump lock pin to pull and twist to lock into open position. This will allow the dump lock plate to release when hoist is raised.

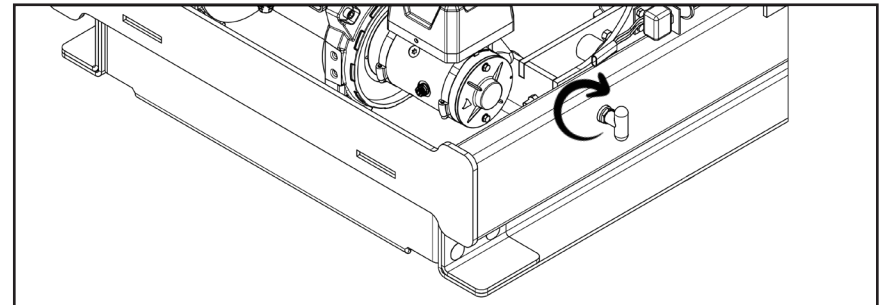

- Step 3—** Connect the control pendant to the control receptacle located inside the vehicle's cab.
- Step 4—** Press the button marked hoist "UP" to approximately 35-45° angle.
- Step 5—** Press the button marked winch "OUT" to allow the body to roll downward off the hoist rollers. The rear rollers of the truck body will touch the ground and continue to move backwards.

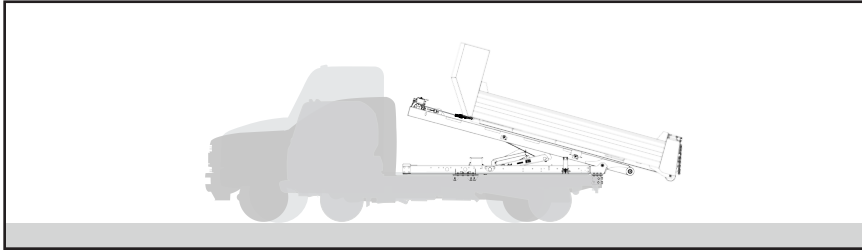

- a** Continue pressing the button until the front of the truck body has completely made contact with the ground.
- b** Once the body has come to a complete rest on the ground, continue winching out a few feet while pulling forward.

- Step 6—** Add slack in the winch cable by either backing the truck up slightly or continuing to press the button marked winch "OUT." Ensure to keep a minimum of 5 wraps of cable on the winch drum.

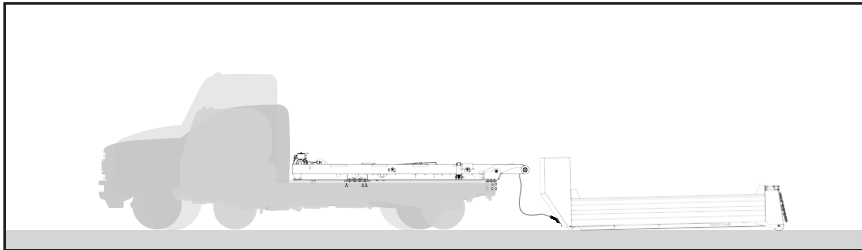

- Step 7—** Disconnect the cable hook from the body and lower hoist to resting position.
- Step 8—** Press the button marked winch cable "IN" while keeping slight tension on the cable with your hands to prevent the cable from dragging on the ground. Always wear protective gloves when handling the winch cable.
- Step 9—** Disconnect pendant controller from the control receptacle and safely stow away inside the cab.

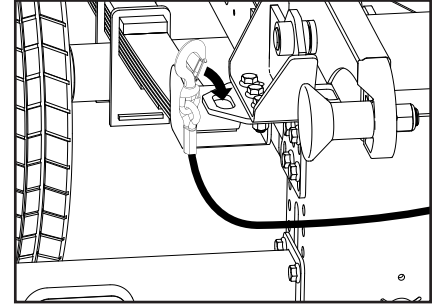



DUMPING CARGO

⚠️ WARNING

Always look to make sure the area and immediate surroundings where you wish to dump are clear, both behind and overhead

Step 1— Ensure there are no over-head obstacles that can be hit by the rising hoist and loaded body.

⚠️ WARNING

The dump lock safety pin must be in the front dump lock at all times during the dumping procedure. Make sure the dump lock safety pin is in the locked position and fully inserted into the top frame.

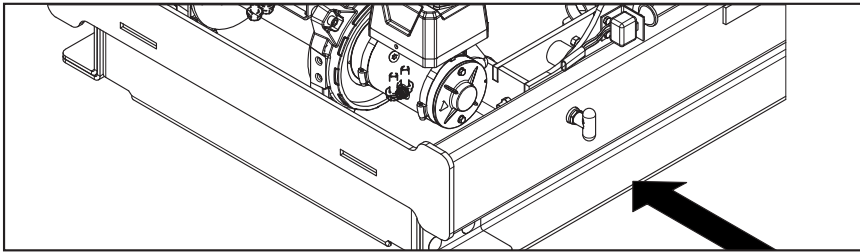

Step 2— Disengage the body tailgate latch and release any safety chains.

Step 3— Connect the control pendant to a control receptacle located inside the vehicle's cab.

Step 4— Press the button marked hoist "UP" to the desired angle (up to 50°) until material starts moving.

Step 5— If the load does not begin to fall from the body, slowly pull the vehicle forward to dislodge the load from the truck body. Watch for overhead obstacles!

Step 6— Once dumping is complete, press the button marked hoist "DOWN".

Step 7— Latch the tailgate shut and secure the safety chains.

Step 8— Disconnect pendant controller from the control receptacle and safely stow away inside the cab.



ATTACHING THE CABLE HOOK

⚠️ NOTICE

Always wear heavy-duty leather gloves when handling the winch cable.

⚠️ NOTICE

Always inspect winch cable for mashed, pinched, or frayed areas when operating the winch as this can severely reduce the strength of the winch cable. Replace the cable if necessary.

Step 1— After the truck is backed up and touching the body, the cable should be at the right length to reach the body. If a little more cable length is needed, press the button marked winch "OUT" while adding tension to the cable. Ensure there is still a minimum of 5 wraps on the winch drum.

Step 2— With the cable hook in hand, locate the load pin at the lower-middle of the truck body front end.

Step 3— Attach the cable hook to the load pin, ensuring the safety keeper is securely closed.

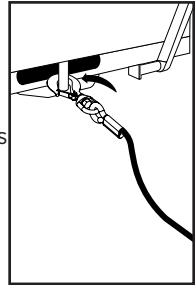

REMOVING THE CABLE HOOK

⚠️ CAUTION

Never touch the winch cable or hook while it is under tension or loaded. The winch cable may have tension, even if at rest.

Step 1— After setting the body on the ground, and slowly pulling ahead while winching out, back the truck up 6"-12", creating slack (no tension) in the cable.

Step 2— Press inward on the safety keeper on the cable hook.

Step 3— Remove the cable hook from the body load pin.

Step 4— Hook the cable hook to one of the rear hold-down points located at the back of the hoist system.

Step 5— If the cable length is too long and is close or is contacting the ground, press the button marked winch cable "IN" while keeping slight tension on the cable with your hands. Some slack in the cable is acceptable. Always wear protective gloves when handling the winch cable.

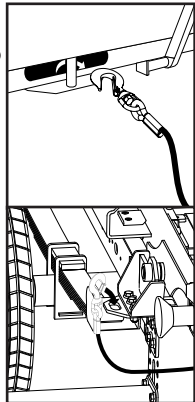



Operational Weight Capacities

CALCULATING THE MAXIMUM CARGO WEIGHT

The legal maximum cargo weight is calculated by subtracting the “Total Unloaded Vehicle Weight” from the “Gross Vehicle Weight Rating”. The “Gross Vehicle Weight Rating” is listed on the tag located on the inside of the driver door. The “Total Unloaded Vehicle Weight” is calculated by finding the sum of the truck’s curb weight, occupants, truck body, the Switch-N-Go® hoist system and upfitted options. See below for EXAMPLES on how to calculate the Legal Maximum Cargo Weight.

! NOTICE

The calculations below are for example only. You will need to calculate your own values based on the truck, type of system, and size of body being used.

Total Unloaded Vehicle Weight

Total Unloaded Vehicle Weight = truck’s curb weight + occupants + body + hoist system

Description	Weight in lbs
Truck curb weight	7,250lbs
Occupants (2 persons weighing approximately 225lbs each)	450lbs
Switch-N-Go® hoist system & 11 ft. dump body w/ rear bumper	3,500lbs
Total Unloaded Vehicle Weight (TUVW)	11,200lbs

Legal Maximum Cargo Weight

Legal Maximum Cargo Weight = Gross Vehicle Weight Rating - Total Unloaded Vehicle Weight

Description	Weight in lbs
Gross Vehicle Weight Rating (GVWR)	19,500lbs
Total Unloaded Vehicle Weight (TUVW)	11,200lbs
Maximum Cargo Volume	8,300lbs



CALCULATING THE ACTUAL CARGO WEIGHT

The actual cargo weight is calculated by taking the vehicle’s Maximum Cargo Volume and multiplying it by the approximate Material Density. (Reference chart on next page for typical material densities.) Compare this Actual Cargo Weight to the calculated Legal Maximum Cargo Weight to verify cargo loads.

Actual Cargo Weight

Actual Cargo Weight = Maximum Cargo Volume x Material Density

Determining Permitted Cargo Weight

Permitted Cargo Weight = Legal Maximum Cargo Weight - Actual Cargo Weight

EXAMPLE 1	
Dump Body Maximum Cargo Volume	2.99 yd ³
Material Density of Sawdust (per chart)	354lbs/yd ³
Actual Cargo Weight (calculated)	1058lbs
Legal Maximum Cargo Weight	8,300lbs
Actual Cargo Weight	1058 lbs.
Difference (LIGHTER than legal maximum)	7,242 lbs.

The actual cargo weight of loaded sawdust is lighter than the legal maximum cargo weight of a 11' dump body, with a difference of 7,242 lbs. This example vehicle cargo weight is legal to haul.

EXAMPLE 2	
Dump Body Maximum Cargo Volume	2.99 yd ³
Material Density of Large Solid Granite (per chart)	4536 lbs/yd ³
Actual Cargo Weight (calculated)	13,563 lbs/yd ³
Legal Maximum Cargo Weight	8,300lbs
Actual Cargo Weight	13,563lbs
Difference (HEAVIER than legal maximum)	-5,263lbs

The actual cargo weight of loaded large limestone is heavier than the legal maximum cargo weight of a 11' dump body, with a difference of 5,263 lbs. This example vehicle cargo weight is NOT legal to haul.



DENSITY OF MATERIALS

Reference Only

Material ¹	(lbs./yd ³)	(kg./m ³)
Alfalfa	432	256
Apples	1080	641
Asbestos - shredded	539	320
Ashes - wet	1230	730
Ashes - dry	961	570
Asphalt, crushed	1215	721
Barley	1027	609
Beans	973	577
Beans, soy	1215	721
Beets	1215	721
Borax, fine	1431	849
Bran	432	256
Brick, common red	3240	1922
Brick, fire clay	4050	2403
Brick, silica	3455	2050
Brick, chrome	4725	2803
Brick, magnesia	4320	2563
Buckwheat	1107	657
Cardboard	1161	689
Cement - clinker	2174	1290
Cement, Portland	2538	1506
Cement, mortar	3644	2162
Cement, slurry	2431	1442
Chalk, solid	4212	2499
Charcoal	351	208
Cinders, furnace	1539	913
Cinders, Coal, ash	1080	641
Clay, dry excavated	1836	1089
Clay, wet excavated	3078	1826
Clay, dry lump	1809	1073
Clay, fire	2296	1362
Clay, wet lump	2700	1602
Clay, compacted	2943	1746
Clover seed	1296	769
Coal, Anthracite, solid	2538	1506
Coal, Anthracite, broken	1863	1105
Coal, Bituminous, solid	2269	1346
Coal, Bituminous, broken	1404	833
Coconut, shredded	593	352
Coffee, fresh beans	946	561
Coffee, roast beans	728	432
Concrete, Asphalt	3781	2243
Concrete, Gravel	4050	2403
Concrete, Limestone/Portland	3996	2371
Copra, medium size	892	529
Copra, meal, ground	1080	641

Cork, solid	405	240
Cork, ground	270	160
Corn, on the cob	1215	721
Corn, shelled	1215	721
Glass, Cullet	2700	1602
Grain, Culum	1269	753
Dolomite, solid	4886	2899
Earth, dry	2105	1249
Earth, moist	2431	1442
Earth, wet	2700	1602
Earth, dense	3374	2002
Earth, mud loose	2916	1730
Earth, packed	2565	1522
Fertilizer, acid phosphate	1620	961
Flaxseed, whole	1215	721
Flour, wheat	1000	593
Garbage/rubbish	811	481
Glass, window	4347	2579
Granite, solid	4536	2691
Granite, broken	2781	1650
Grain - Maize	1281	760
Grain - Barley	1011	600
Grain - Millet	1281	760
Grain - Wheat	1315	780
Gravel, loose, dry	2565	1522
Gravel, with sand, natural	3240	1922
1/4-2" size gravel, dry	2835	1682
Gravel, wet 1/4 to 2 inch	3374	2002
Gypsum, solid	4698	2787
Gypsum, broken	2174	1290
Gypsum, crushed	2700	1602
Gypsum, pulverized	1890	1121
Halite (rock salt), broken	2538	1506
Ice, solid	1549	919
Ice, crushed	1000	593
Lignite, dry	1350	801
Lime, quick, lump	1431	849
Lime, quick, fine	2024	1201
Lime, stone, large	4536	2691
Lime, stone, lump	2592	1538
Lime, hydrated	811	481
Lime, wet or mortar	2596	1540
Limestone, solid	4401	2611
Limestone, broken	2619	1554
Limestone, pulverized	2350	1394
Linseed, whole	1269	753



Malt	566	336
Manure	674	400
Marble, solid	4320	2563
Marble, broken	2646	1570
Mica, solid	4859	2883
Mica, broken	2700	1602
Mica - flake	876	520
Mortar, wet	4050	2403
Nickel silver	14229	8442
Oats	728	432
Oats, rolled	512	304
shells, ground	1431	849
Paper,	2024	1201
Peanuts, shelled	1080	641
Peanuts, not shelled	458	272
Peat, dry	674	400
Peat, moist	1350	801
Peat, wet	1890	1121
Pitch	1943	1153
Plaster	1431	849
Potatoes, white	1296	769
Pumice, stone	1080	641
Rubber, caoutchouc	1593	945
Rubber, manufactured	2565	1522
Rubber, ground scrap	811	481
Rye	1188	705
Saltpeter	2024	1201
Sand, wet	3240	1922
Sand, wet, packed	3509	2082
Sand, dry	2700	1602
Sand, packed	2835	1682
Sand, water filled	3240	1922
Sand with stone/gravel, dry	2781	1650
Wet Sand with Gravel, wet	3405	2020
Sandstone, solid	3916	2323
Sandstone, broken	2309	1370
Sawdust	354	210
Shale, solid	4509	2675
Shale, broken	2673	1586
Slate, solid	4536	2691
Slate, broken	2174	1290
Slate, pulverized	2296	1362
Snow	811	481
Soda Ash, heavy	1820	1080
Soda Ash, light	728	432
Rocks/Stones	4239	2515

Tar	1943	1153
Trap rock, solid	4859	2883
Trap rock, broken	2943	1746
Turf	674	400
Dry Black Walnuts	1027	609
Wheat	1296	769
Wheat, cracked	1134	673
Wool	2215	1314
Wool	82	1314

Wood ²	(lbs./yd ³)	(kg./m ³)
Apple	1112	660
Ash, black	910	540
Ash, white	1129	670
Aspen	708	420
Balsa	287	170
Bamboo	506	300
Birch (British)	1129	670
Cedar, red	641	380
Cypress	860	510
Douglas Fir	893	530
Ebony	1618	960
Elm (Wych)	1163	690
Elm (Rock)	1374	815
Iroko	1104	655
Larch	994	590
Lignum Vitae	2158	1280
Mahogany (Honduras)	919	545
Maple	1273	755
Oak	994	590
Oak (Red)	1188	705
Pine (Oregon)	893	530
Pine (Canadian)	590	350
Pine (Red)	624	370
Redwood (American)	758	450
Spruce (Canadian)	758	450
Spruce (Sitka)	758	450
Sycamore	994	590
Teak	1112	660
Willow	708	420
Pecan wood	1269	753
Bark, wood refuse	405	240
Cottonwood	701	416

© Simetric.co.uk (2016, July 15). Density of Materials-Material or Alloy. Retrieved from https://www.simetric.co.uk/si_metrics.htm, © Simetric.co.uk (2016, February 24). Density of Materials-Wood. Retrieved from https://www.simetric.co.uk/si_wood.htm

REPLACEMENT PARTS

We have built your vehicle to the highest standards using quality parts. Contact your local dealer for information about replacement parts by directly reaching out to us.



SCAN THIS CODE

to locate a dealer or visit us at switchngo.com/locator

Contact us toll-free at (888) 311-0867

E-SERIES HOIST SYSTEM PARTS

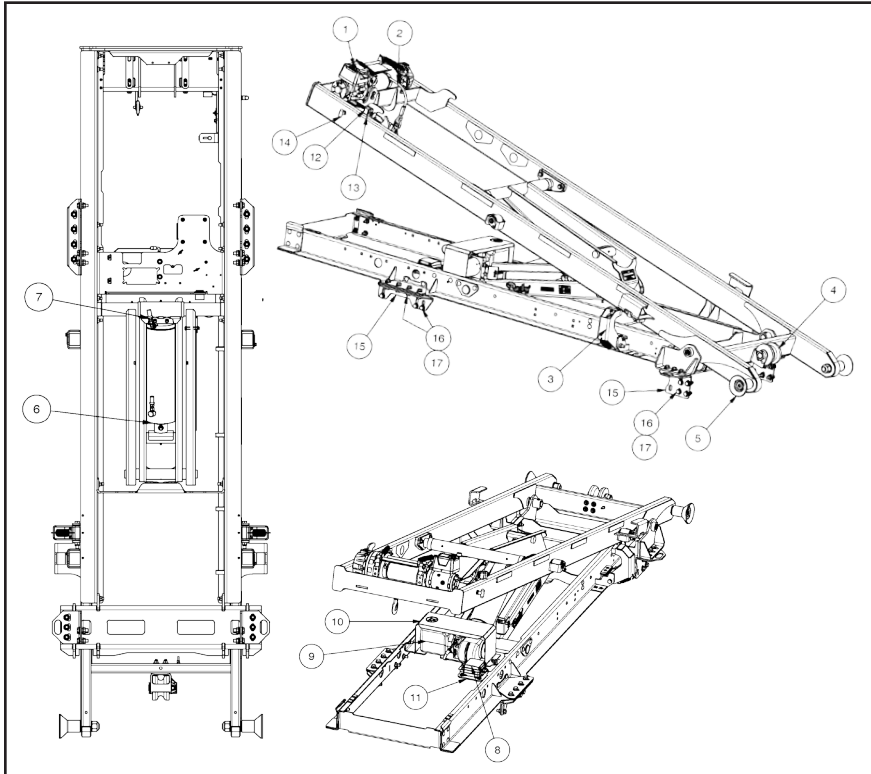

E-SERIES HOIST SYSTEM PARTS

ITEM	Part Number	Description
1	3210132	15K Electric Winch Assembly
2	1600000	1/2" Cable (25') w/ Swivel Hook
3	4600765	6" ProLoC
4	4600007	Cable V-Roller Assembly
5	4600682	Greaseable Rear Yellow Roller
6 A	1810013	SR4016 Hydraulic Cylinder
6 B	1810014	SR4020 Hydraulic Cylinder
6 C	1810015	SR5020 Hydraulic Cylinder
7 A	HOIST SPECIFIC	Hydraulic Hose w/ Fittings
7 B	HOIST SPECIFIC	Hydraulic Hose w/ Fittings
8	3790000	Electrical Junction Box
9	4600013	Hydraulic Pump w/ Tank and Wiring Harness
10	2721289	Cover for Hydraulic Manifold
11	2721474	Mounting Plate for Hydraulic Manifold
12	3790033	Winch Stop Switch
13	2720296	Mounting Bracket for Winch Stop Switch
14	1600134	Spring Plunger w/ Lockout
15	See pg. 40	Chassis Specific Mounting Brackets
16	9120087	1.75" Flanged Bolt for Mounting Bracket
17	9340021	Serrated Flanged Nut for Mounting Bracket
	3790069	Controller, Wired Pendant, Gen 3

CALL SUPPORT FOR HOIST SPECIFIC PARTS: 888-311-0867



H-SERIES HOIST SYSTEM PARTS

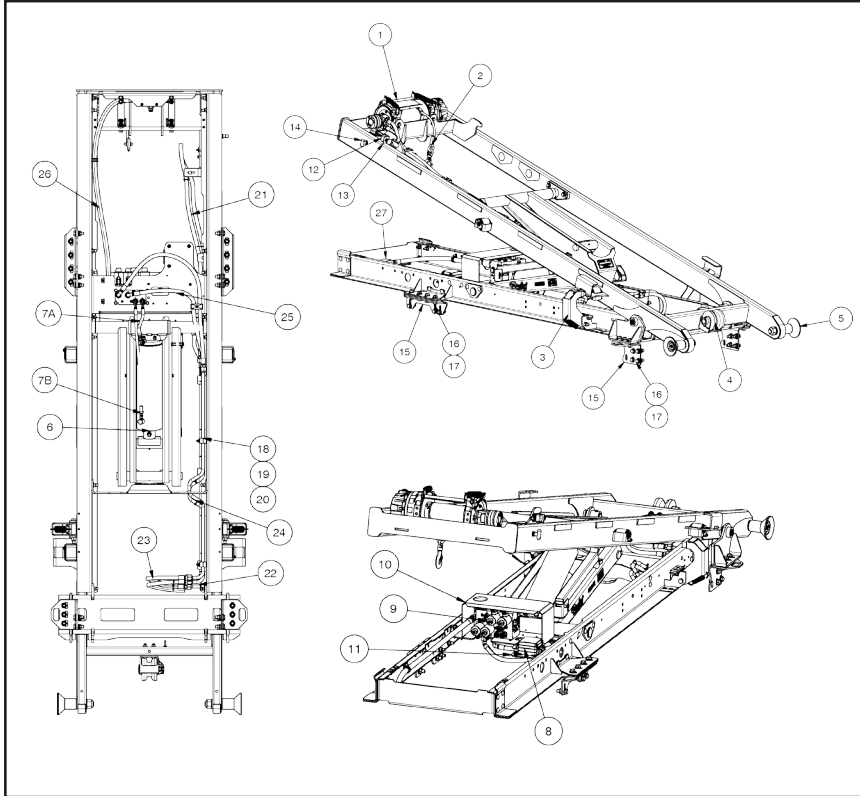

H-SERIES HOIST SYSTEM PARTS

ITEM	Part Number	Description
1 A	3210136	15K Hydraulic Winch Assembly
1 B	3210138	18K Hydraulic Winch Assembly
2	1600000	1/2" Cable (25') w/ Swivel Hook
3	4600765	6" ProLoC
4	4600007	Cable V-Roller Assembly
5	4600588	Greaseable Rear Yellow Roller
6 A	1810013	SR4016 Hydraulic Cylinder
6 B	1810014	SR4020 Hydraulic Cylinder
6 C	1810015	SR5020 Hydraulic Cylinder
7 A	HOIST SPECIFIC	Hydraulic Hose w/ Fittings
7 B	HOIST SPECIFIC	Hydraulic Hose w/ Fittings
8	3790000	Electrical Junction Box
9 A	1730044	Hydraulic Manifold
9 B	3170153	Hydraulic Manifold Harness
10	2721289	Cover for Hydraulic Manifold
11	2721474	Mounting Plate for Hydraulic Manifold
12	3790033	Winch Stop Switch
13	2720296	Mounting Bracket for Winch Stop Switch
14	1600134	Spring Plunger w/ Lockout
15	See pg. 40	Chassis Specific Mounting Brackets
16	9120087	1.75" Flanged Bolt for Mounting Bracket
17	9340021	Serrated Flanged Nut for Mounting Bracket
18	1600013	Vibration-Damping Clamp
19	9190126	Clamp Carriage Bolt
20	9430003	Clamp Nylock Nut
21	HOIST SPECIFIC	Flexible, Hydraulic Tube, Top Frame
22	4870523	Fixed, Hydraulic Tube, Top Frame
23	4870003-3	Flexible, Hydraulic Tube, Top Frame to Bottom Frame
24	4870510	Fixed, Hydraulic Tube, Bottom Frame
25	HOIST SPECIFIC	Flexible, Hydraulic Line, To Pump
26	HOIST SPECIFIC	Flexible, Hydraulic Line, From Filter
27	4870009	Filter, Reusable In-line High Pressure
	3790069	Controller, Wired Pendant, Gen. 3

CALL SUPPORT FOR HOIST SPECIFIC PARTS: 888-311-0867



MOUNTING BRACKET INFORMATION

BRACKET KITS BOLT ON 60CA

4850526: FORD F450-F600 60CA
4850533: FORD F350 60CA
4850528: RAM 4500/5500 60CA
4850529: RAM 3500 60CA
4850532: GM 4500/5500 60CA
4850531: GM 3500 60CA

BRACKET KITS BOLT-ON 84CA+

4850005: FORD F450-F600
4850006: RAM PRIOR-2021
4850525: RAM 2022- PRESENT
4850007: GM/INTERNATIONAL
4850536: ISUZU 2014-PRESENT

BRACKET KITS WELD-ON

4850003: ISUZU
4850008: UNIVERSAL BRACKETS



BODY PROP ROD WARNINGS & USE

Federal Regulation 29 CFR 1926.601, (b)(10) states “Trucks with dump bodies shall be equipped with positive means of support, permanently attached, and capable of being locked in position to prevent accidental lowering of the body while maintenance or inspection work is being done.” Accordingly, all hoist systems will include a body prop rod for a positive means of support. The purpose of the body prop rod is to provide a safety strut for supporting the hoist system when maintenance or repairs are performed. The body prop rod must be used when maintenance requires the hoist to be in a raised position. The body prop rod is for use only when the truck body is empty or removed. Ensure to read all the warning, caution, and danger labels before operating your hoist system.

⚠ DANGER

The body prop rod is only to be used to prop an unloaded body or an empty hoist system itself. Serious injury or death may occur if the body prop rod is misused.

⚠ WARNING

Do not place arms, hands, any part of the body, or objects between the Switch-N-Go® hoist system’s top frame and subframe without the body prop rod engaged.

⚠ CAUTION

Do not power the winch system while the body is on the body prop rod.

OPERATE THE BODY PROP ROD

- Step 1—** Using the control pendant, raise the hoist system "UP" halfway to approximately 25° angle which reveals about 8" of the cylinder stroke, sufficient height to engage the prop rod.
- Step 2—** Rotate the prop rod counterclockwise until it is in a vertical position.
- Step 3—** Engage body prop rod by lowering it into the pocket.
- Step 4—** Lower the hoist system "DOWN" until the upper lift tube is nestled in the prop rod cup.
- Step 5—** Disconnect any power to the control pendant and vehicle so that the hoist system is not operated accidentally.
- Step 6—** To lower or disengage the body prop rod, operate this procedure in reverse.

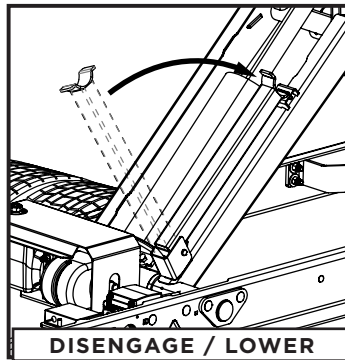
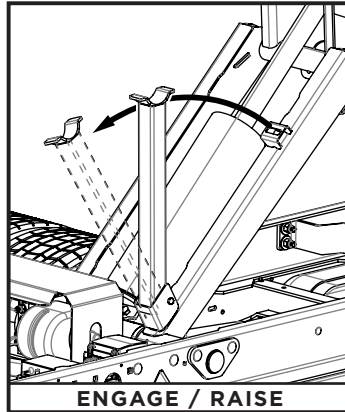
**SYSTEM MAINTENANCE**

Routinely maintain your hoist system and winch by observing the weekly, monthly, and yearly checklists. All hoist systems generally require very little periodic maintenance, but there are a few actions that should be taken to ensure that it is always in top working condition.

WEEKLY

- Inspect the winch cable for visible damage such as kinks, knots, mashed or frayed portions and broken strands every time the winch is operated. If the winch cable is damaged, replace before it breaks under load as this could result in serious injury or damage. Follow replacement procedure on page 45.
- Inspect the winch brake for slippage or cable drifting on a regular basis by visually observing the winch brake while operating the winch under load. If the winch drum continues to turn more than a 1/4 revolution in 15 minutes after the button is released, the brake may need to be replaced. Reference the Warn® brake service kit instructions for replacement procedure.

MONTHLY

- Inspect and regrease all scissor hoist grease fittings as shown in the grease fitting diagram on page 48. Apply rust-preventing lubrication to the following:
 - Front dump lock
 - Yellow rear rollers
 - Body rear ground rollers and nose rollers
 - Electrical connections
 - All moving parts
- Lubricate the winch cable per Lubricate Your Winch Cable instructions on page 49.
- Inspect all rollers and roller shafts for excessive wear or fractures. Replace any parts or components that are damaged, broken, or working improperly. Reference the spare parts diagram on page 36-39 or contact your local dealer for more information.

- Check hydraulic fluid levels. If fluid is needed, follow the procedure on page 46-47.
- Inspect all bolts, nuts, and rollers on the hoist system. Ensure they are tightened to the proper torque. See reference chart on page 52. Replace any damaged, broken bolts, or fasteners with grade 5 or better.
- Inspect hydraulic fittings and hoses for cracks or damage.
- Inspect all electrical wiring on the hoist system and accessories for damage by checking lights and controls are in proper working order.

YEARLY

- Replace the hoist system's hydraulic fluid, referencing the procedure found on pages 46-47.
- Fully inspect the vehicle chassis and Switch-N-Go® hoist system frame for cracks, deformation, or excessive wear. If the system or vehicle shows signs of damage, refer to the Troubleshooting section or contact your local dealer for more information.

WINCH CABLE REPLACEMENT

This winch cable replacement is for Warn® 15,000lbs or 18,000lbs winches.

The cable feeds out from the topside of the Switch-N-Go® hoist systems' winch

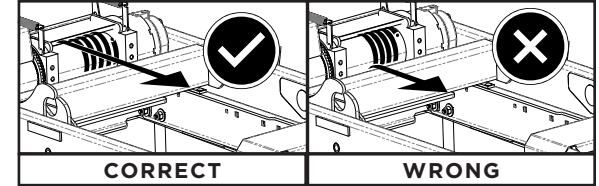

! WARNING

Always maintain a minimum of five wraps of the cable on the drum while operating the winch. Failure to do so may result in the cable to pull free of the winch drum and drop the load.

WINCH CABLE INSTALLATION

- Step 1—** With the hoist system in the full-lowered position, wind the winch "OUT" until the cable is no longer wrapped around the winch drum.
- Step 2—** With an Allen wrench, loosen or remove the set screw holding the end of the cable in the winch drum. This is located on the passenger side of the winch drum.
- Step 3—** Remove and discard the old winch cable.
- Step 4—** Wrap a 1" piece of masking tape around the end of the NEW wire winch cable to prevent fraying during installation.
- Step 5—** Insert the taped wire cable into the cable anchor hole located on the passenger side of winch drum. Tighten the set screw with an Allen wrench and torque to 12-15 ft-lbs. Ensure you do not over-tighten the set screw as this may result in a stripped or damaged screw.
- Step 6—** Wind the winch "IN", coiling the wire cable as it feeds onto the winch drum. Add slight tension to the cable by holding the end with protective gloves. The coil must always maintain a minimum of 5 wraps on winch drum.
- Step 7—** Clean any excessive lubrication with a dry cloth from hoist system/ vehicle components once cable is fully coiled around the winch drum.



HOIST SYSTEM HYDRAULIC FLUID CHANGE

Use Oil equivalent to Grade 32 (such as ATF-Dextron II or Mobile DTE-13)

E-series Hydraulic Fluid Capacities

E-SERIES	Hoist Model	Reservoir Tank (Quarts)	Approximate System Oil Capacity (Quarts)
	4016	3.5	4.5
	4020	3.5	6
	5020	3.5	9

E-series

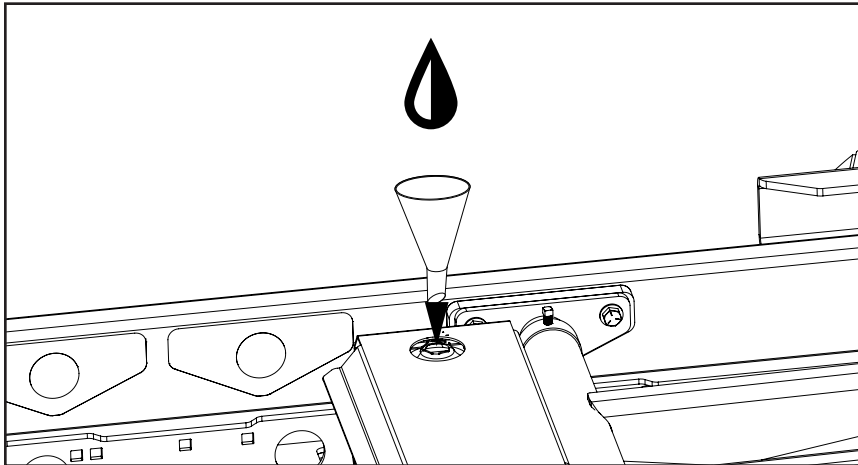

H-series Hydraulic Fluid Capacities

H-SERIES	Hoist Model	Reservoir Tank (Gallons)	Approximately System Oil Capacity (Gallons)
	4016	15-20	1 + vehicle's tank capacity
	4020	15-20	1.5 + vehicle's tank capacity
	5020	15-20	2.25 + vehicle's tank capacity



⚠ WARNING

When performing maintenance on the hoist in the raised position, ensure the truck body is removed, and that the body prop rod is securely in place.

- Step 1—** This procedure requires there be no truck body on the hoist. Unload the body by following the procedures on pages 27-29 of this manual.
- Step 2—** Stow away the body prop rod and lower the hoist all the way down flat.
- Step 3—** Remove breather cap on hydraulic reservoir tank.
- Step 4—** Using a siphon pump, remove all the old fluid from the hydraulic tank.
- Step 5—** Completely fill the hydraulic tank with hydraulic oil equivalent to Grade 32 (such as ATF-Dextron II or Mobile DTE 13).
- Step 6—** Raise the hoist "UP" halfway to approximately 25° angle which reveals about 8" of the cylinder stroke.
- Step 7—** Rotate the prop rod counterclockwise until it is in a vertical position and engage it by lowering it into the pocket.
- Step 8—** Lower the hoist "DOWN" until the upper lift tube is nestled in the prop rod cup.
- Step 9—** Continue to fill the Hydraulic reservoir leaving 1/2" void from the top of the reservoir. Carefully loosen the feed line on the hydraulic hoist cylinder, until a small amount of hydraulic oil weeps out, removing any trapped air pockets.
- Step 10—** Ensure all feed and return lines are tight and not leaking.
- Step 11—** Cycle the hoist system "UP" and "DOWN" and continue filling the reservoir tank leaving 1/2" from the top.
- Step 12—** Replace and tighten the breather cap on the reservoir tank.
- Step 13—** Lift the hoist "UP", disengage the prop rod and continue to lower the hoist "DOWN", checking the operation.



LUBRICATING THE HOIST SYSTEM & BODIES

Lubrication is vital to preventing premature wear as this may result in hoist system malfunction or system failure

- Lubricate all grease fittings as shown below with premium automotive or marine grease.
 - (3) Grease fittings are located on the lower shaft scissor hoist connected to the bottom hoist frame.
 - (2) grease fittings are located on the top frame and bottom of the middle section of the scissor hoist
 - (2) Grease fittings are located on the upper shaft scissor hoist connected to the top hoist frame

All Switch-N-Go® truck bodies' moving parts are equipped with grease fittings and should be lubricated according to the System Maintenance schedule. Specifically make sure body nose rollers and rear ground rollers stay lubricated.

GREASE FITTING DIAGRAM

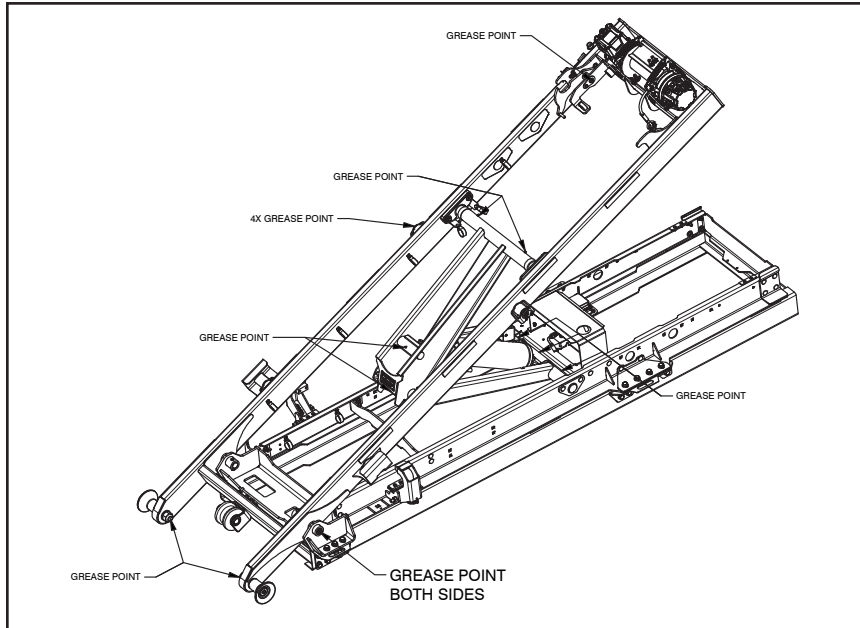

LUBRICATING THE WINCH CABLE

! NOTICE

The surface of the cable may become covered with dirt, rock dust or other material during their operation. Be sure to clean the cables before applying lubrication to ensure proper penetration.

The lubricant you apply should be light bodied enough to penetrate to the cable's core. You can normally apply lubricant by dripping it on the cable, spraying it on, or brushing it on. In all cases, you should apply it at a place where the cable is bending, such as around a sheave to more easily penetrate the cables's core.

! NOTICE

Never apply heavy grease to the cable because it can trap excessive grit, which can damage it. Nor should you apply used "engine oil" because it contains materials that can damage the cable.



SYSTEM TEST & PRE-OPERATION CHECKLIST

Failure to properly test and check the system may result in premature wear, improper functionality, or a system failure.

- Ensure you have been properly instructed how to operate the Switch-N-Go® upfitted vehicle.
- Ensure you have been instructed how to connect the control pendant into the proper receptacle or power on and off the wireless control pendant.
- Ensure you have been instructed how to load and unload truck bodies using the hoist system both empty and loaded.
- Ensure you are aware of the GVWR, TUVW, hoist system weight, load capacities of the hoist system and the vehicle. Information is located on the vehicle's driver inside pillars or inside the door panel.
- Check all nuts and bolts are properly torqued, using the torque chart on shown on page 52.
- Check to make sure all electrical connections and wires are tight and free from all pinching or cutting hazards, as this may lead to malfunctions or damage.
- Check to make sure the body prop rod is safely installed and is working properly.
- Check all grease fittings are lubricated with either premium automotive or marine grease.
- Check the winch cable is fastened tightly and spools evenly around the drum.
- Ensure the winch cable has minimum of 5 spools around the drum remaining when fully extended.



- When retracting the winch cable, ensure it spools evenly around the winch drum
- Check that the batteries and fuses are connected and are working properly.
- Check that all hydraulic fittings are free of leaks. When checking for leaks please wear protective eye wear and gloves to protect face and hands from high pressure leaks.
- Check all high pressure hoses that are connected to the hoist, vehicle, and/or hydraulic system.
- Test that the control pendant functions are working properly.
- Test the system to its maximum operating dump angle by pressing the button marked "UP" on the control pendant to raise it up to 50°. Then press "DOWN" to return the hoist the horizontal position.

TORQUE TABLE

Size	Grade 2		Grade 5		Grade 8		18-8 S/S	
	Coarse	Fine	Coarse	Fine	Coarse	Fine	Coarse	Fine
#4*	—	—	—	—	—	—	5.2	—
#6*	—	—	—	—	—	—	9.6	—
#8*	—	—	—	—	—	—	19.8	—
#10*	—	—	—	—	—	—	22.8	31.7
1/4"	4	4.7	6.3	7.3	9	10	6.3	7.8
5/16"	8	9	13	14	18	20	11	11.8
3/8"	15	17	23	26	33	37	20	22
7/16"	24	27	37	41	52	58	31	33
1/2"	37	41	57	64	80	90	43	45
9/16"	53	59	82	91	115	129	57	63
5/8"	73	83	112	128	159	180	93	104
3/4"	125	138	200	223	282	315	128	124
7/8"	129	144	322	355	454	501	194	193
1"	188	210	483	541	682	764	287	289

*Size from 4-10 are in lb-in
Size from 1/4 up are lb-ft

†Fine thread figures are 1-14
Grade 2,5 & 8 values are plated bolts

CONTROL PENDANT PIN-OUT DIAGRAM

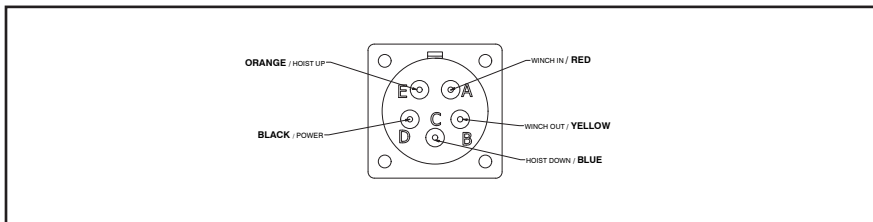

SYSTEM DIAGRAM {E-SERIES}

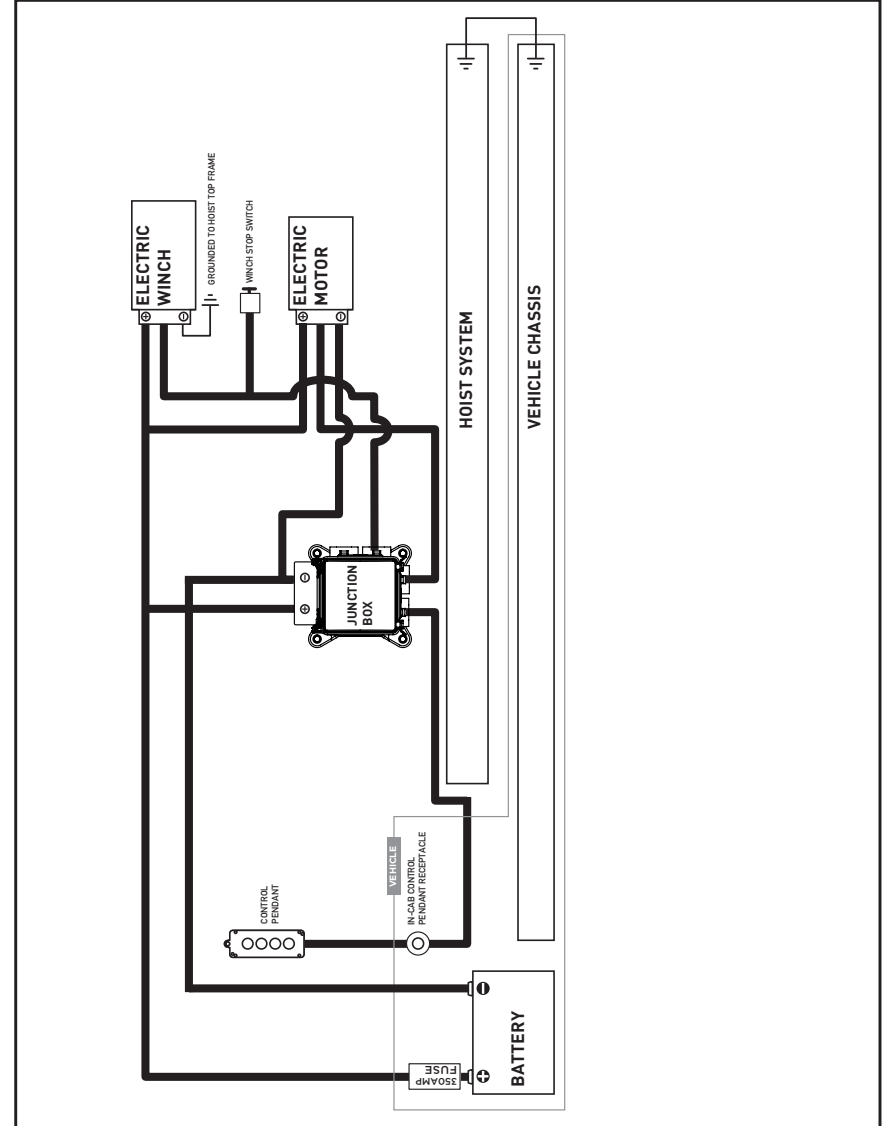

SYSTEM DIAGRAM {H-SERIES}

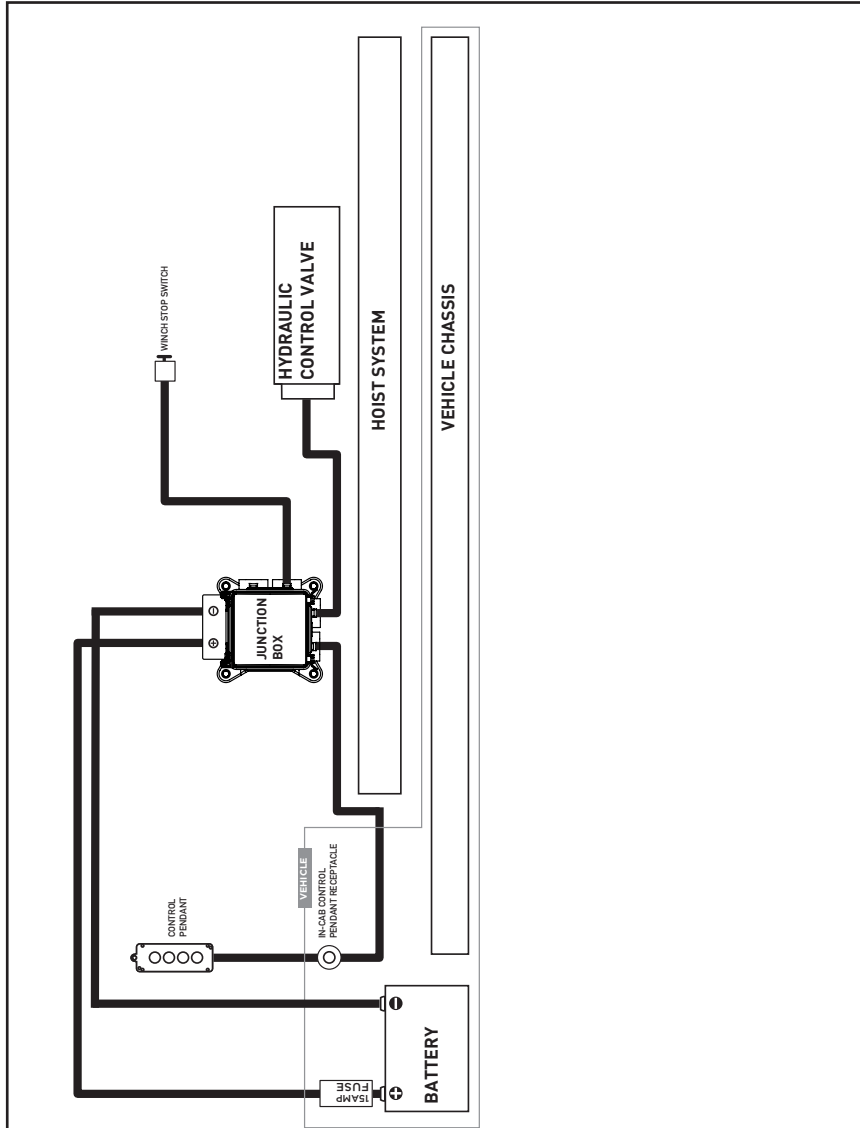

TROUBLESHOOT

If you're having issues with your hoist system, use our interactive troubleshoot guide at the link below.



SCAN THIS CODE

to troubleshoot your hoist system or visit us at portal.switchngo.com

E-series | Electric over hydraulic system

Behavior of Problem	Cause of Problem	Solution (Instructions or see reference)
Neither winch nor hoist will respond or is weak	Control pendant disconnected or defective	Disconnect and reconnect control pendant Check pendant plug to make sure all (5) pins are not bent, broken, or pushed back
	12V DC power disconnected	Check all power and ground terminal connections Check for and replace blown fuse (350A) Check wire harness connections at junction box
	Weak vehicle batteries	Test vehicle batteries with voltmeter and replace if needed Ensure vehicle battery requirements are satisfied

Behavior of Problem	Cause of Problem	Solution (Instructions or see reference)
Hoist will not raise or lower	Bad ground wire connection	Check ground connections at vehicle battery, hoist junction box, winch, pump motor, and hoist frame to chassis
	Defective coil (black-box coil, qty 2)	Swap with other coil to determine which one may be defective Replace defective coil
	Body prop rod is engaged or is in the "UP" position	Disengage body prop rod and return to the "DOWN" position
	Foreign obstruction between top frame and subframe of the hoist system.	Remove any tools, wires, hoses, or other foreign objects from the hoist system
Weak/no hoist operation	Pump motor not functioning	Replace Bucher pump motor or hydraulic pump assembly
Winch will not move in either direction	Vehicle battery(s) disconnected	Check 350A fuse Replace fuse if blown Reconnect vehicle battery
	Defective Warn relay block	Replace Warn relay block
	Malfunctioning stop switch (Winch will not winch in)	Check wiring to stop switch Replace winch stop switch assembly
	Warn winch motor is defective	Replace Warn winch motor
Winch spools out under load	Winch brake clutch slipping	Replace brake clutch in winch
	Winch gears damaged	Contact your dealer
Hoist system is acting sporadically	Defective diodes in junction box	Use a multimeter to determine which diode is defective Replace defective diode(s)
Breather cap pops off hydraulic tank	Pump was dead headed Load too heavy Dirty fluid	Flush and replace fluid 3/4 full Do not over fill Replace breather cap

H-series | Full hydraulic system

Behavior of Problem	Cause of Problem	Solution (Instructions or see reference)
Neither winch nor hoist will respond or is weak	Control pendant disconnected or defective	Disconnect and reconnect control pendant. Check pendant plug to make sure all (5) pins are not bent, broken, or pushed back.
	12V DC power disconnected	Check all power and ground terminal connections Check for and replace blown fuse (15A) Check wire harness connections at junction box
	Dirty hydraulic fluid	Check filters, flush and refill hydraulic fluid Remove valve, clean to ensure it is not plugged
		Lack of hydraulic fluid flow
Hoist will not raise or lower	Broken or cut hydraulic line	Repair leaks or dry-rot cracks in hydraulic lines
	Body prop rod is engaged or is in the "UP" position	Disengage body prop rod and return to the "DOWN" position
	Foreign obstruction between top frame and subframe of the hoist system.	Remove any tools, wires, hoses, or other foreign object from the hoist system



Behavior of Problem	Cause of Problem	Solution (Instructions or see reference)
Winch will not move in either direction	Battery(s) is disconnected	Check 15A fuse Replace fuse if blown Reconnect battery
	Malfunctioning stop switch (Winch will not winch in)	Check wiring to stop switch Replace winch stop switch assembly
	Winch motor is defective	Replace the winch motor
Winch spools out under load	Winch brake clutch slipping	Replace brake clutch in winch
	Winch gears damaged	Contact your dealer
Hoist system is acting sporadically	Defective diodes in junction box	Use a multimeter to determine which diode is defective Replace defective diode(s)
	Loose junction box connection	Check/ Tighten power and ground connectors at junction box

PROUDLY
MADE
SAEGERTOWN, PA



switchngo.com • 888-311-0867
607 Erie Street Saegertown, PA 16433